

# 18/24 Gallon Dual Push Door

## RECTANGULAR STAINLESS STEEL TRASH CAN with AbsorbX® Odor Control and Wheels

Offer quick and effective waste disposal in entry ways, lobbies, stores and more, with the HLS Commercial Dual Push Door Trash Can. The elegant, durable stainless steel complements any decor, while the double side opening allows for convenient disposal in high-traffic venues.



**HLS18DPO**

**HLS24DPO**

### FEATURES

- ✓ LARGE 18 AND 24 GALLON CAPACITY
- ✓ DUAL SIDE ENTRY PUSH DOORS
- ✓ ABSORBX ODOR FILTER NEUTRALIZES TRASH ODORS
- ✓ WHEELS ALLOW FOR EASY MOBILITY
- ✓ FINGERPRINT-PROOF AND SMUDGE-RESISTANT STAINLESS STEEL

# SPECIFICATIONS

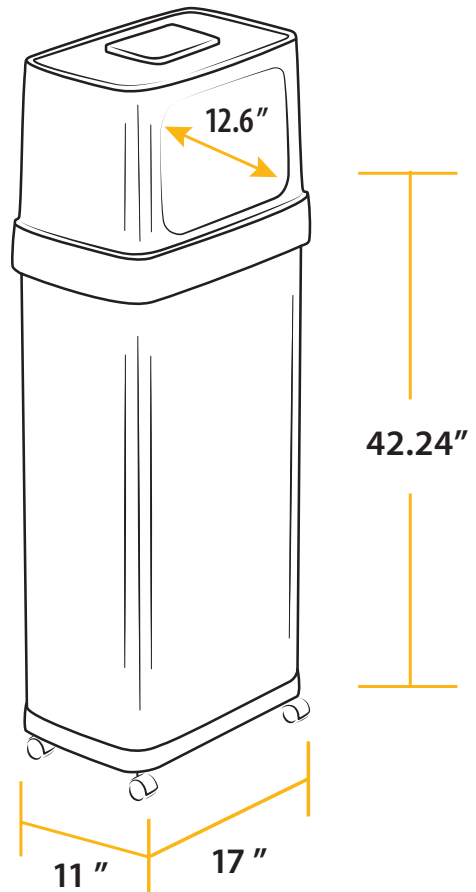
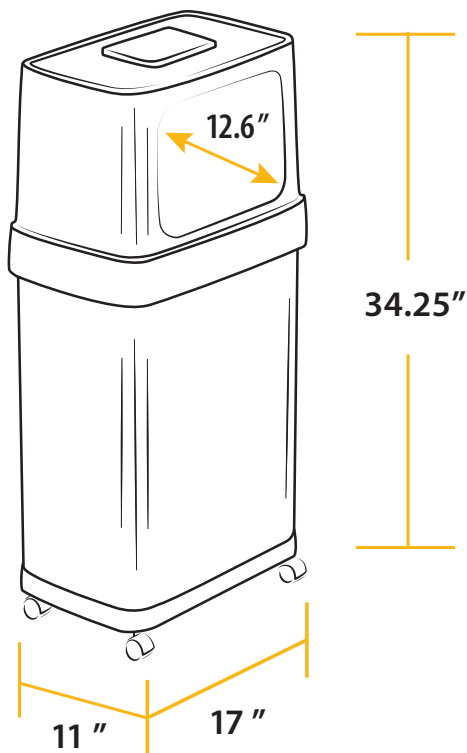

**Model:** HLS18DPO

**Dimensions:**  
17" L x 11" W x 34.25" H

**Package Dimensions:**  
17.5" L x 12.2" W x 27.4" H

**Product Weight:** 7.9 lbs.

**Package Weight:** 10.6 lbs.

**Capacity:**  
18 Gallons (68 Liters)

**Material:** Stainless Steel

**Model:** HLS24DPO

**Dimensions:**  
17" L x 11" W x 42.24" H

**Package Dimensions:**  
17.5" L x 12.2" W x 35.4" H

**Product Weight:** 9.9 lbs.

**Package Weight:** 14.3 lbs.

**Capacity:**  
24 Gallons (91 Liters)

**Material:** Stainless Steel