

8 Gallon/30 Liter Stainless Steel ROUND SENSOR TRASH CAN

Eliminate exposure to the illness-causing bacteria that live on trash can surfaces with this touchless, sensor-operated trash can. Enhanced infrared sensor technology allows for hands-free lid open and close, promoting a healthier environment. The odor filter compartment houses the easy to replace AbsorbX® odor filter to absorb and neutralize trash odors. An extra-large 10" opening easily accommodates large and bulky items. It's perfect for high-traffic venues that require quick and easy disposal. It also features an enhanced lid hinge mechanism and air vent holes for effortless trash bag removal.



FEATURES

- ✓ **NO-TOUCH LID OPERATION FOR ENHANCED HYGIENE**
- ✓ **DURABLE MATERIAL/CONSTRUCTION; EASY TO SERVICE**
- ✓ **WIDE OPENING ACCOMMODATES LARGE AND BULKY ITEMS**
- ✓ **REPLACEABLE ODOR FILTER ABSORBS TRASH ODORS**
- ✓ **SLIM AND SPACE-SAVING DESIGN**
- ✓ **TRASH BAG RETAINER RING KEEPS BAG IN PLACE AND OUT OF VIEW**
- ✓ **STAINLESS STEEL IS FINGERPRINT-PROOF AND EASY TO CLEAN**

SPECIFICATIONS

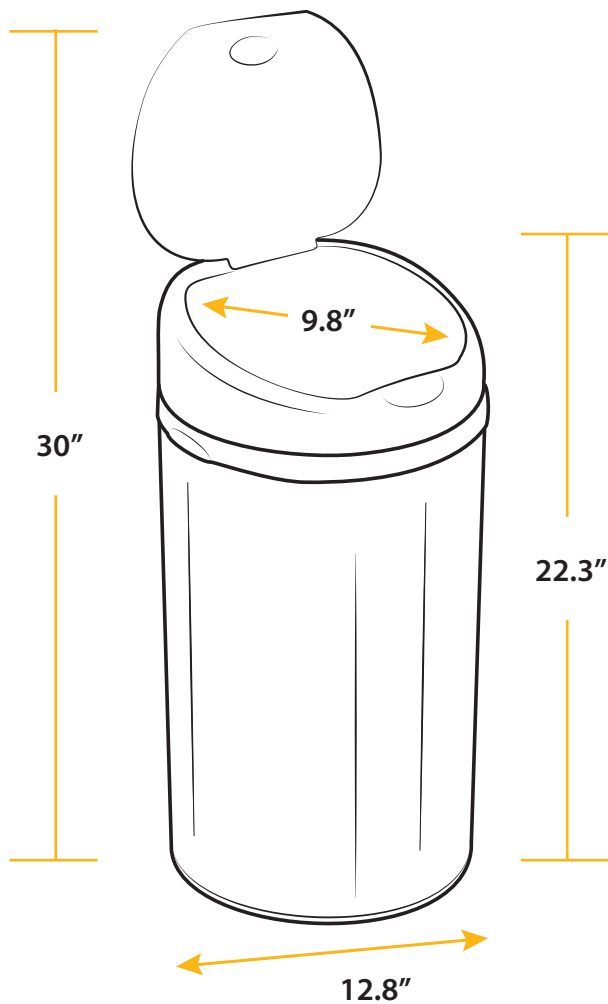

AbsorbX® Replaceable Odor Filter

Model: HLS08RCB

Dimensions: 12.8" L x 12" W x 22.3" H

Package Dimensions: 13" L x 13" W x 24" H

Product Weight: 6.6 lbs.

Package Weight: 10 lbs.

Capacity: 8 Gallons (30 Liters)

Material: Stainless Steel / ABS Plastic (Top)

UnoClean.com
(224) 654-6500