



MADE
IN THE **USA**

Alternate Products (each sold separately):

- GL300-0212: Glove Box Dispenser - Triple with Dividers Quartz Beige ABS Plastic (shown below)
- GL030-0223: Glove Box Dispenser - Triple with Dividers BOWMAN® Signature Series - Maple Fauxwood ABS Plastic
- GL030-0233: Glove Box Dispenser - Triple with Dividers BOWMAN® Signature Series - Cherry Fauxwood ABS Plastic



Product Description:

- Glove Box Dispenser - Triple with Dividers
- Holds three boxes of gloves
- Three-way keyholes for vertical or horizontal wall mounting
- Semi-Transparent, Injection Molded Polycarbonate Plastic

Primary Area for Product Usage:

- All primary care areas: clinic/exam rooms, radiology, labs, physical therapy, OR areas, employee health
- Kitchens, laundry facilities, environmental services, sterile processing

Dispenses:

- Box(es) no larger than 5.25"W x 10.00"H x 3.75"D (13.3 cm x 25.4 cm x 9.5 cm)
- Box(es) no smaller than 4.50"W x 8.50"H x 2.50"D (11.4 cm x 21.6 cm x 6.4 cm)

Package Specifications:

- Package Quantity: 6 per case
- 21"W x 14"H x 10"D (53.3 cm x 35.6 cm x 25.4 cm)
- 10.0 lbs (4.5 kg) - approximated

Product Specifications (overall external dimensions):

- 17.08"W x 10.11"H x 4.22"D (43.4 cm x 25.7 cm x 10.7 cm)
- 1.4 lbs (0.6 kg) - approximated

Mounting Specifications:

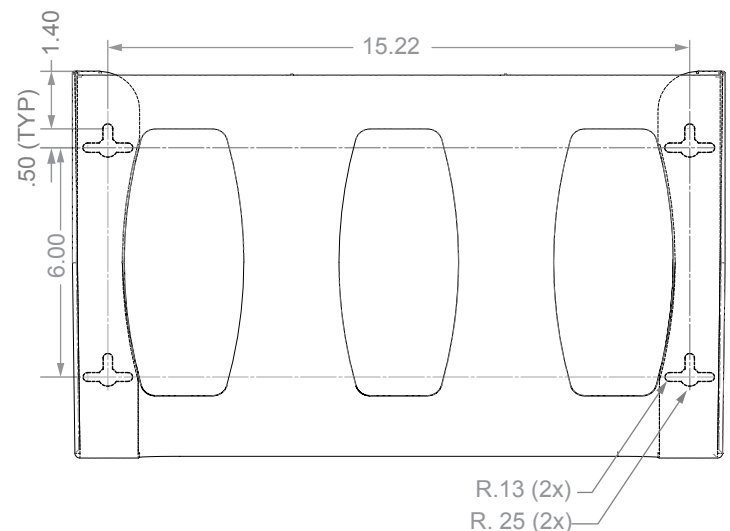



Installation

Always mount dispensers securely *prior* to loading with product.

- Dividers between sections for quick, effortless stocking regardless of mounting position.
- Dispenser can be mounted horizontally, or vertically with either a left or right loading position.

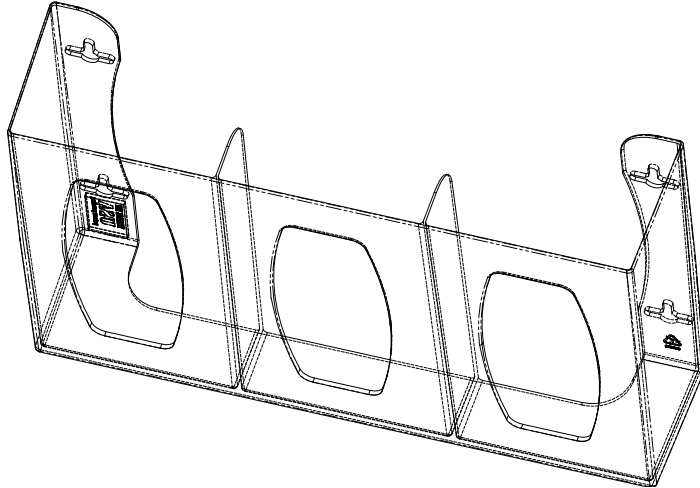

- Mount securely to a wall or cabinet with screws approved and supplied by building maintenance.

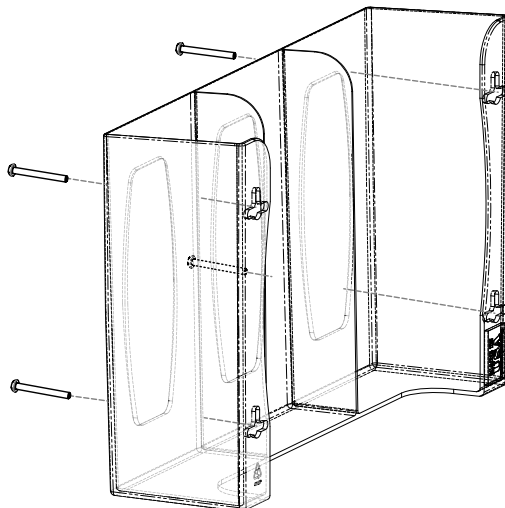

Parts included:

- Dispenser

Tools Required:

- No tools required to assemble dispenser

Care and Construction

Polycarbonate

Material Characteristics

Designed for Long-Term Use

Polycarbonate plastic is a polymer comprised of Bisphenol A and phosgene, which makes it shatter resistant and provides an excellent combination of strength, rigidity, and toughness. It is a frosted, lightweight, tough, dimensionally stable thermoplastic. It is also temperature and humidity resistant and will perform exceptionally under heavy, long-term use.

As polycarbonate is virtually unbreakable, it is safe to use in areas where it may be exposed to impact. These qualities make it perfect for a wide variety of applications, including medical and laboratory equipment.

Frosted polycarbonate plastic makes an attractive display. The transparency allows the viewer to see content, read text, and see true colors through the material.

Care and Cleaning

Resistant to stains, polycarbonate is easily cleaned with common cleaners or mild soap and water. Alcohol is recommended to remove grease or oil. Ammonia and acetone should not be used.